

P610 SERIES (Press-Fit Type)

SPECIFICATION

Insulator Material : PBT+30%GF UL94V-0
 Contact Material : Phosphor Bronze
 Plating : Selective Gold Plating Over Nickel On Contact Point
 100µ" Tin Plating On Tail Section
 50µ" Nickel Underplating
 Current Rating : 3 Ampere
 Insulation Resistance : 5000 megohms minimum
 Dielectric Withstanding Voltage : 1000 VAC RMS
 Operation Temperature Range : -55°C to +105°C
 Insertion Force (Max.) : 32 LBS
 Withdrawal Force (Min.) : 7 LBS

ORDERING INFORMATION

P610 - 50 - □ - 1

Terminal Style	Insulator Style
10 : Straight Press-Fit Type	1 : Rounded Edge
No. of Contacts	Plating
50	1 : 10µ" 4 : 5µ" 7 : Tin overall
	2 : G/F 5 : G/F overall 8 : 15µ"
	3 : 3µ" 6 : 30µ" 9 : 20µ"

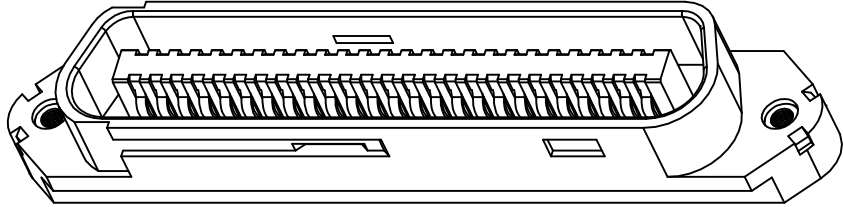
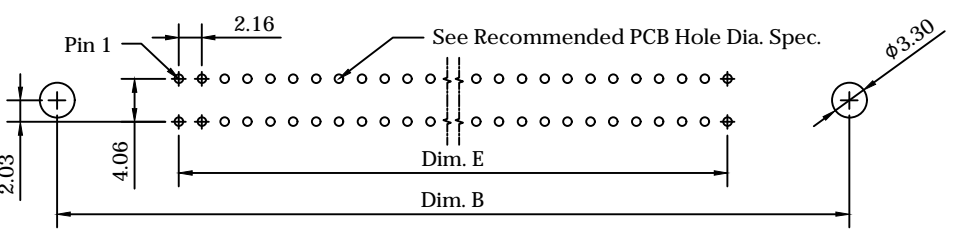
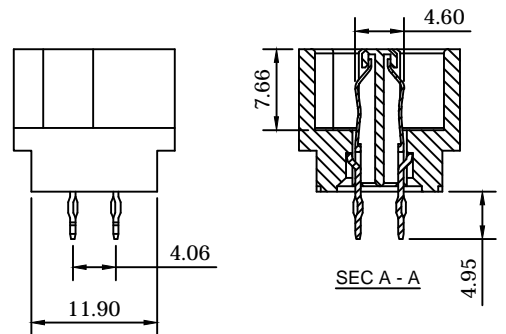
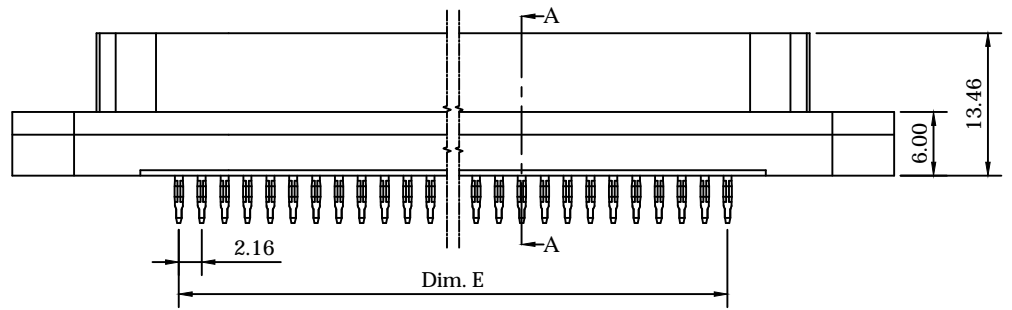
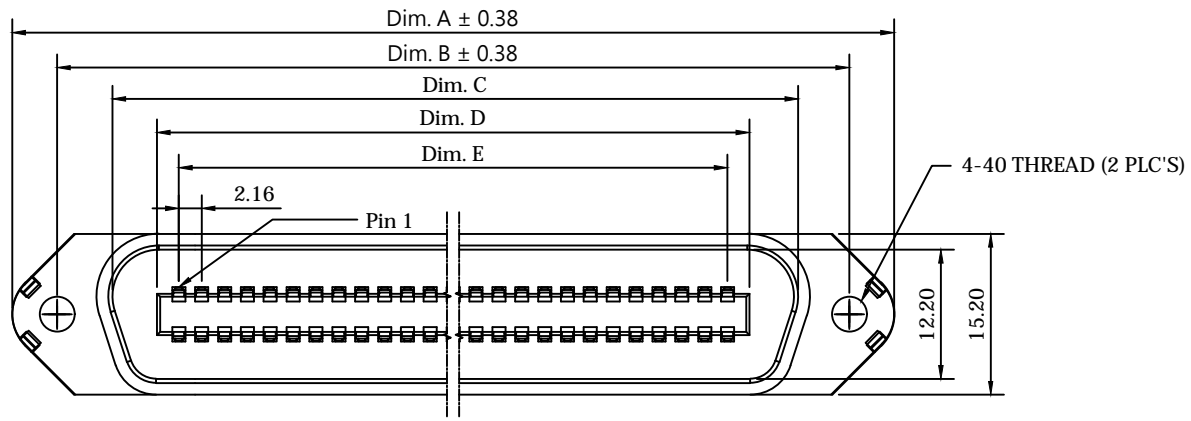

RECOMMENDED HOLE DIAMETER

- Before thru-hole plating : 0.965±0.025
- Copper Plating Thickness : 0.025~0.051
- Solder Plating Thickness : 0.0076~0.03
- Finish Hole diameter must be gaged to $\phi 0.81^{+0.08}_{-0.05}$

No. of Contacts	Dimensions (Dim.)				
	A	B	C	D	E
25/50	83.30	74.84	64.55	56.20	51.84

Title : Customer Drawing Type : Centronic Connector
 Part No. : P610 Series (Press-Fit Type)
 Description :
 Pitch 2.16 mm Centronic Connector Male Press-Fit Type
 Row To Row 4.06 mm, Tail Length 4.50 mm
 Round Edge Type Insulator
 DWG No. : 010 - 0000 - P610-1 Date : 26 - Oct. - 2017
 APPD. : James C. CHK. : Connie Z. DRW. : Bryant C.



Tolerances Unless Otherwise Specified :
 X. ± 0.50 .X ± 0.38 .XX ± 0.25
 X.° ± .X° ± .XX° ±

Dim.	Scale	Sheet	Rev.
mm	N/A	1 of 1	A